

FR



- Contrôler le contenu de votre colis avant de procéder au montage.
- Ne détériorez pas l'emballage, il vous sera très utile pour protéger les éléments des coups et rayures pendant le montage.
- Assemblez ensuite le meuble en suivant l'ordre défini par la numérotation.
- En cas de problème contactez notre service après vente.
- Du fait de son confinement dans le carton après emballage, il est possible qu'au déballage et au montage votre produit dégage dans l'air des odeurs de vernis, plus ou moins prononcées. Afin que ces odeurs ne vous incommodent pas, nous vous conseillons de disposer votre produit dans une pièce convenablement et régulièrement aérée, en ouvrant complètement les portes et en déposant les tiroirs à côté du meuble, jusqu'à disparition de ces odeurs.

ES



- Controlar el contenido de su embalaje antes de proceder al montaje.
- No deteriorar el paquete, que le será muy útil para proteger los elementos de golpes y rozaduras durante el montaje..
- Acoplar de seguida el mueble, siguiendo la orden definida por la numeración.
- Si tiene problemas, contactar nuestro servicio postventa.
- Dado que el mueble ha permanecido encerrado en la caja de cartón desde el momento de su acondicionamiento, es posible que al desembalarlo desprenda a la atmósfera un olor a barniz más o menos pronunciado. Con el fin de evitar que esos olores sean para usted una incomodidad, le aconsejamos dejar el producto en un lugar adecuado y regularmente aireado: abrir por completo las puertas, retirar los cajones y dejarlos aireándose junto al mueble, hasta que tales olores hayan desaparecido.

EN



- Check the content of your parcel before assembling.
- Do not throw away the packing which could be very useful to protect the panels from knocks and scratches when assembling.
- Assemble the article following the order of the numbers indicated.
- Should any problems arise, please contact our After Sales Service.
- You may notice a smell of varnish when you unpack your item, due to its having been stored in a box since its packaging. In order to avoid any inconvenience that may be caused by such odours, we recommend that you place the item in a well ventilated room, opening all doors, and removing the drawers from the cabinet, until any such odours have dissipated.

PT



- Confira o conteúdo da sua encomenda antes de iniciar a montagem.
- Não danifique a embalagem, poderá ser-lhe útil para proteger os elementos de golpes ou riscos durante a montagem.
- Proceda à montagem do móvel seguindo a ordem definida pela numeração.
- Para qualquer esclarecimento, contacte os nossos serviços através do telefone.
- Devido ao seu encerramento na caixa de cartão após o acondicionamento, é possível que, no momento da desembalagem e montagem do produto, este lance para o ar um cheiro a verniz, mais ou menos intenso. Para que este cheiro não o incomode, aconselhamos-lhe a colocar o produto num compartimento adequado e regularmente arejado, deixando as portas totalmente abertas e colocando as gavetas ao lado do móvel, até que o referido cheiro desapareça..

NL



- De inhoud van uw pakket controleren alvorens met de montage te beginnen.
- De verpakking niet beschadigen, deze kan heel handig zijn om de onderdelen te beschermen tegen schokken en krassen tijdens de montage.
- Zet vervolgens het meubel in elkaar in de volgorde die is bepaald in de nummering.
- Neem bij problemen contact op met onze klantenservice.
- Het is mogelijk dat zich bij het uitpakken en in elkaar zetten van uw product een min of meer uitgesproken laklucht verspreidt. Om te voorkomen dat u last heeft van deze lucht, raden we u aan om uw product in een voldoende en regelmatig geventileerde ruimte neer te zetten. Doe daarbij de deurtjes helemaal open en zet de laden naast het meubel neer totdat deze lucht is verdwenen.

DE



- Vor Montage den Inhalt Ihres Päckchens kontrollieren.
- Die Verpackung nicht zerstören, sie wird Ihnen nützlich sein, um die Teile bei der Montage vor Stößen und Kratzern zu schützen.
- Das Möbel dann in der Reihenfolge der Nummerierung zusammenbauen.
- Im Problemfall Ihren Kundendienst anrufen.
- Da das Möbelstück eine gewisse Zeit lang eng verpackt war, ist nicht auszuschließen, dass sich beim Auspacken und der Montage ein mehr oder minder starker Lackgeruch entwickelt. Damit der Lackgeruch Sie nicht stört, empfehlen wir Ihnen, Ihren Einrichtungsgegenstand in einen gut und regelmäßig gelüfteten Raum zu stellen, die Schubladen herauszunehmen und die Türen ganz zu öffnen, bis sich der Lackgeruch vollständig verflüchtigt hat.

IT



- Verificare il contenuto della confezione prima del montaggio.
- Non eliminare l'imballo che potrà essere utilizzato per proteggere il prodotto dai danni durante il montaggio.
- Montare l'articolo seguendo l'ordine di numerazione.
- In caso di necessità contattare il nostro servizio post-vendita.
- Per il fatto di essere rimasto chiuso nel cartone dopo l'imballaggio, è possibile che il mobile una volta liberato dal cartone e durante il montaggio sprigioni nell'aria odori di vernice più o meno forti. Affinché questi odori non Le creino fastidio, raccomandiamo di collocare il prodotto in un locale adeguatamente e regolarmente aerato, aprendo completamente le porte e depositando i cassetti accanto al mobile fino alla scomparsa degli odori.

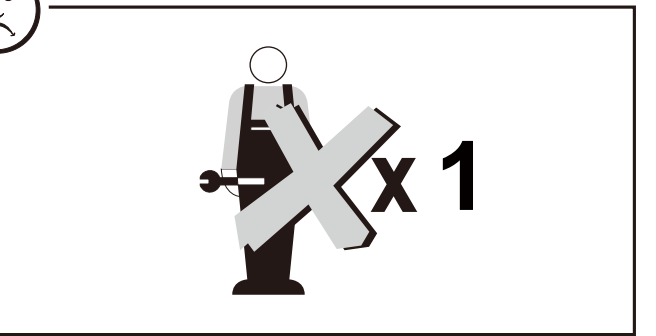
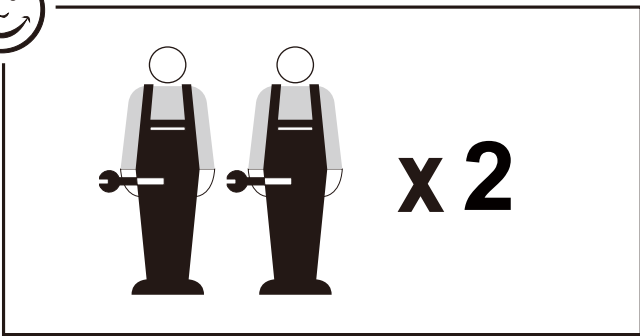
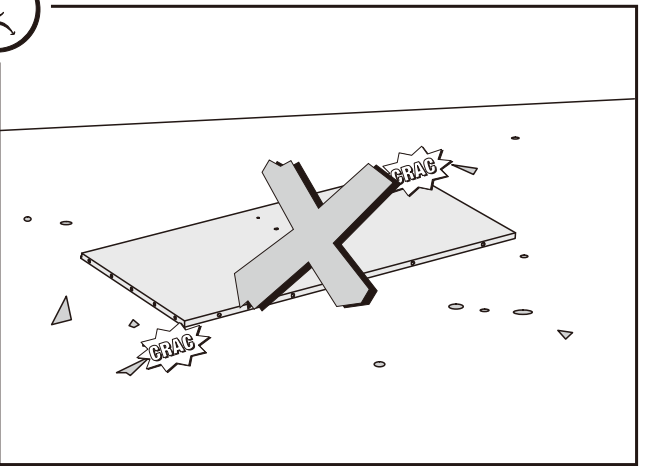
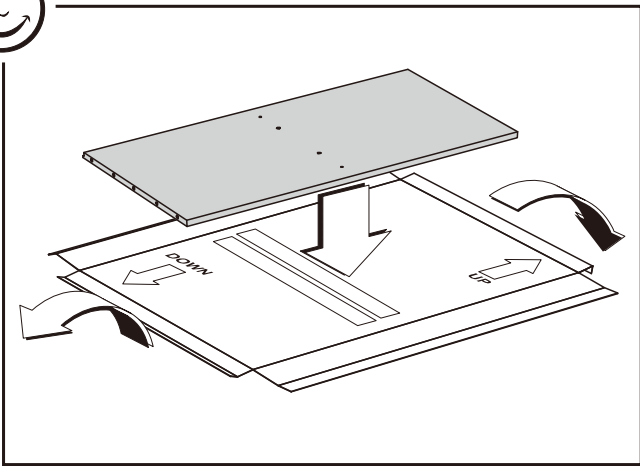
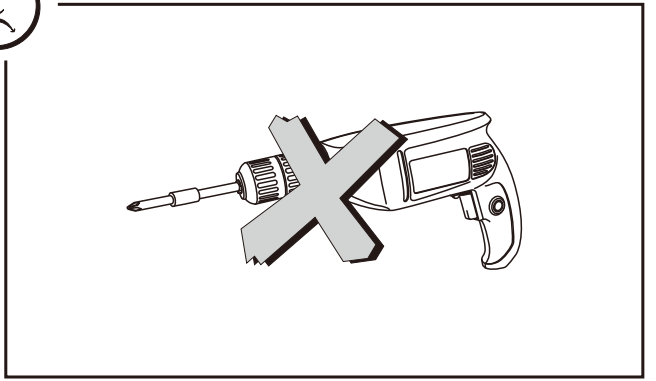
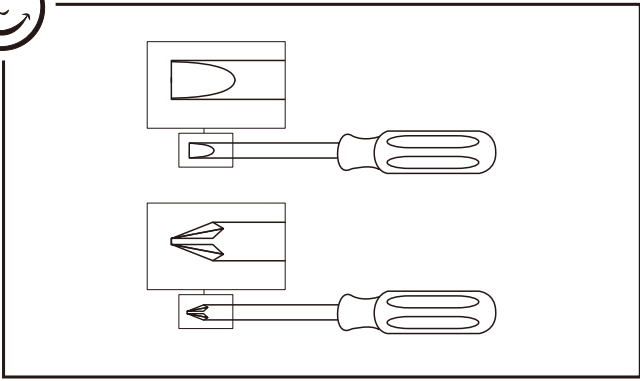

# FR - IMPORTANT ! A LIRE ATTENTIVEMENT ET A CONSERVER EN VUE D'UNE CONSULTATION ULTERIEURE

- A monter par un adulte. Un adulte doit vérifier le bon assemblage avant l'emploi
- ATTENTION! tenir les vis et petits éléments et sachets hors de portée des enfants
- Bien identifier les éléments avant de commencer le montage
- En cas de problème contactez notre service après-vente
- Toujours suivre les instructions du fabricant
- Ne pas monter sur le produit
- Entretien: nettoyer avec un chiffon doux et sec. En cas de taches plus grosses, frottez soigneusement avec une éponge légèrement humide et non abrasive
- AVERTISSEMENT - Si ce produit est placé sous une fenêtre, il peut servir de marche à l'enfant et entraîner sa chute par la fenêtre
- AVERTISSEMENT - Tenir compte des risques engendrés par la présence de foyers ouverts ou autres sources de forte chaleur à proximité immédiate du produit
- AVERTISSEMENT - NE PAS placer ce produit à proximité d'une fenêtre où les cordons de stores ou de rideaux pourraient étrangler un enfant
- Il convient de toujours serrer correctement tous les dispositifs d'assemblage
- Ne pas utiliser ce produit si une pièce est cassée, déchirée ou manquante et utiliser uniquement des pièces de rechange approuvées par le fabricant
- Âge de l'enfant auquel le siège est destiné : ≥ 6 ans
- Conforme à la norme EN 17191 :2021
- Charge maximale : 75 kg

# EN - IMPORTANT! READ CAREFULLY AND KEEP FOR FUTURE REFERENCE

- To be assembled by an adult. Assembly must be checked by an adult before use
- WARNING! keep all screws, small parts and plastic bags out of the reach of children
- Properly identify all parts before assembling
- Should any problems arise, please contact our After Sales Service
- Manufacturer's instructions shall be followed at all times
- Do not climb on the product
- Care: clean with a soft, dry cloth. In case of larger stains, carefully rub with a slightly damp, non-abrasive sponge
- WARNING - If this product is located under a window, it can be used as a step by the child and cause the child to fall out of the window
- WARNING - Be aware of the risk of open fires and other sources of strong heat in the vicinity of the product

- WARNING - DO NOT place this product near a window where cords from blinds or curtains may strangle a child
- All assembly fittings should always be tightened properly
- Do not use the product if any part is broken, torn or missing and use only spare parts approved by the manufacturer
- Age of the child for which the seating is intended:  $\geq 6$  years
- Complies with standard EN 17191 :2021
- Maximum loading : 75 kg

## PT - IMPORTANTE! LEIA ATENTAMENTE E GUARDE PARA CONSULTA FUTURA

- A ser montado por um adulto. Um adulto deve verificar a boa montagem antes da utilização
- ATENÇÃO! mantenha os parafusos, acessórios pequenos e saco de plástico fora do alcance das crianças
- Identifique bem os acessórios antes de começar a montagem
- Para qualquer esclarecimento, contacte os nossos serviços através do telefone
- As instruções do fabricante devem ser sempre cumpridas
- Não suba para cima do produto
- Manutenção: limpe com um pano macio e seco. Em caso de manchas maiores, esfregue cuidadosamente com uma esponja ligeiramente húmida e não abrasiva
- AVISO - Se este produto for colocado sob uma janela, pode servir de degrau à criança e fazer com que caia da janela
- AVISO - Tenha em conta os riscos provocados pela presença de chamas livres e outras fontes de calor intenso na proximidade do produto
- AVISO - NÃO coloque este produto na proximidade de uma janela onde as fitas das persianas ou das cortinas possam estrangular a criança
- Todos os acessórios de montagem devem ser sempre fixados corretamente
- Não utilize este produto se uma peça estiver partida, rasgada ou em falta e utilize apenas peças de substituição aprovadas pelo fabricante
- Idade da criança à qual o assento se destina:  $\geq 6$  anos
- Em conformidade com a Norma EN 17191 :2021
- Carga máxima: 75 kg

## ES - ¡IMPORTANTE! LEA DETENIDAMENTE ESTAS INDICACIONES Y GUÁRDELAS PARA FUTURAS CONSULTAS

- A montar por un adulto. Un adulto debe comprobar el buen montaje antes de la utilización
- ¡ADVERTENCIA! mantener los tornillos, los pequeños elementos y bolsitas fuera del alcance de los niños
- Identificar debidamente los elementos antes de empezar el montaje
- Si tiene problemas, contactar nuestro servicio postventa
- Deben seguirse siempre las instrucciones del fabricante
- No subir sobre el producto
- Cuidados: limpiar con un paño suave y seco. En caso de manchas grandes, frotar con cuidado utilizando una esponja húmeda no abrasiva
- ADVERTENCIA: Si se coloca el producto bajo una ventana, el niño podría subirse y caer por la ventana

- ADVERTENCIA: Tenga en cuenta el riesgo que generan las llamas abiertas y otras fuentes de calor intenso cerca del producto
- ADVERTENCIA: NO coloque este producto cerca de una ventana donde los cordones de los estores o de las cortinas puedan estrangular a un niño
- Todos los elementos de montaje deberán estar siempre correctamente apretados
- No utilice el producto si alguna pieza está rota, rasgada o falta; y utilice únicamente piezas de repuesto aprobadas por el fabricante
- Edad del niño o la niña a quien se destina el asiento:  $\geq 6$  años
- Conforme a la norma EN 17191 :2021
- Carga máxima : 75 kg

## DE - WICHTIG! AUFMERKSAM LESEN UND FÜR SPÄTERES NACHLESEN AUFBEWAHREN

- Von einem Erwachsenen zu montieren. Die korrekte Montage muss vor Gebrauch von einem Erwachsenen geprüft werden
- ACHTUNG! die Schrauben und kleinen Teile ausserhalb der Reichweite von Kindern lagern
- Vor Montagebeginn alle Teile identifizieren
- Im Problemfall Ihren Kundendienst anrufen
- Stets die Herstelleranweisungen beachten
- Nicht auf das Produkt steigen
- Wartung: Mit einem weichen, trockenen Tuch reinigen. Bei größeren Flecken vorsichtig mit einem leicht feuchten, nicht scheuernden Schwamm abreiben
- WARNHINWEIS - Wenn das Produkt unter einem Fenster steht, kann es von einem Kind als Stufe genutzt werden und dazu führen, dass das Kind aus dem Fenster stürzt.
- WARNHINWEIS - Achten Sie auf Risiken, die durch offene Kamine oder andere starke Hitzequellen in der Nähe des Produkts entstehen können.
- WARNHINWEIS - Dieses Produkt nicht in der Nähe eines Fensters aufstellen, wo die Kordeln von Rollos oder Vorhängen eine Strangulationsgefahr für ein Kind darstellen.
- Alle Befestigungen sollten immer ordnungsgemäß festgezogen werden.
- Dieses Produkt nicht benutzen, wenn ein Teil gebrochen, gerissen ist oder fehlt. Nur vom Hersteller zugelassene Ersatzteile verwenden.
- Alter des Kindes, für das die Sitz bestimmt ist:  $\geq 6$  Jahre
- Entspricht der Norm EN 17191 :2021
- Höchstlast : 75 kg

## IT - IMPORTANTE! LEGGERE CON ATTENZIONE E CONSERVARE PER FUTURO RIFERIMENTO

- Il montaggio deve essere eseguito da un adulto. Un adulto dovrà verificare il corretto montaggio prima dell'uso
- ATTENZIONE! tenere le viti ed i componenti di piccole dimensioni lontano dalla portata dei bambini
- Controllare i pezzi prima del montaggio
- In caso di necessità contattare il nostro servizio post-vendita
- Seguire sempre le istruzioni del costruttore







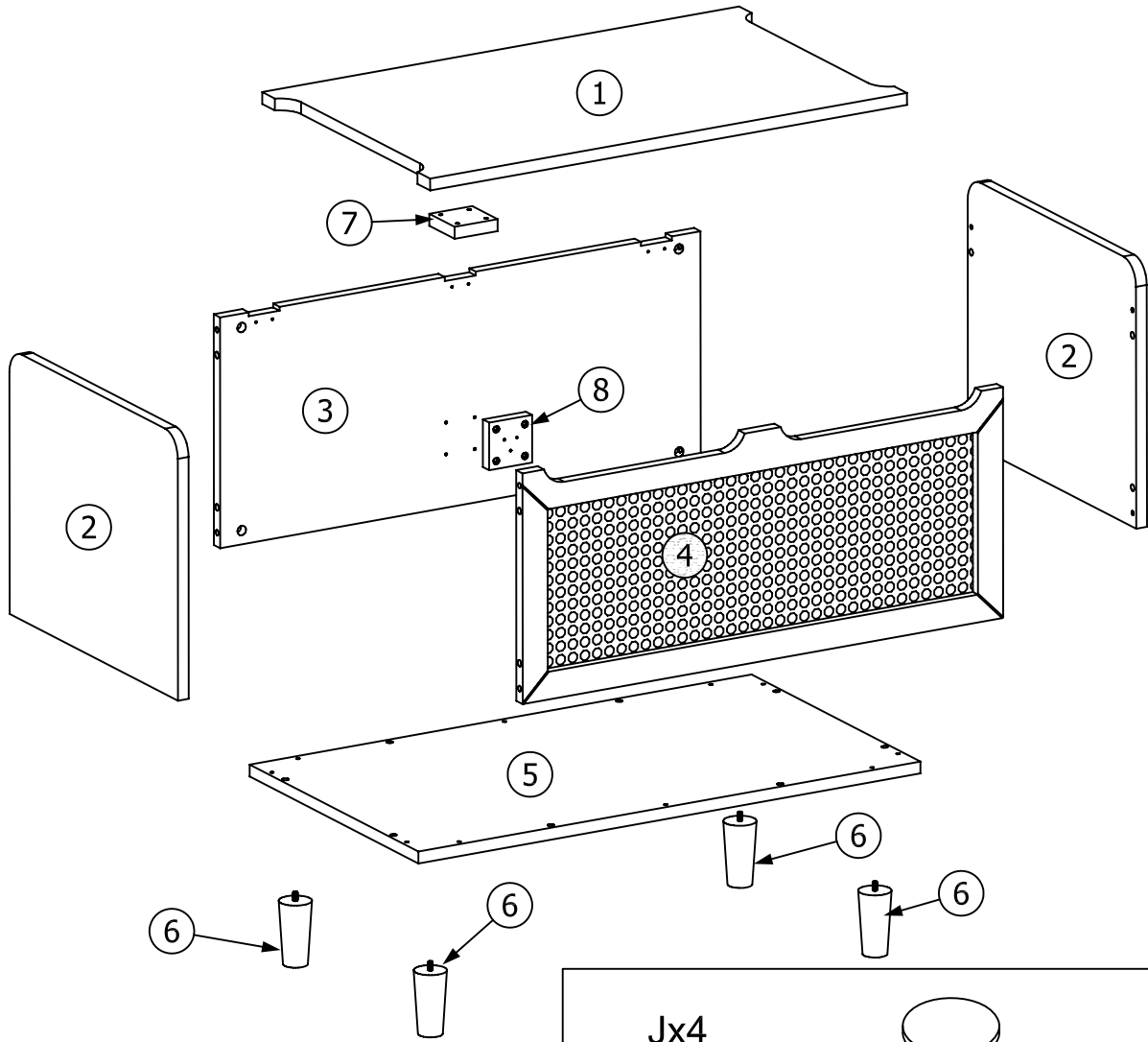

- Non salire sul prodotto
- Manutenzione: pulire con un panno morbido e asciutto. Per le macchine più grandi, strofinare accuratamente con una spugna leggermente umida e non abrasiva
- AVVERTENZA - Se questo prodotto è collocato sotto una finestra, può essere utilizzato dal bambino come base per arrampicarsi, con conseguente rischio di caduta dalla finestra
- AVVERTENZA - Tenere conto dei rischi connessi alla presenza di fiamme libere o altre fonti di forte calore nelle vicinanze del prodotto.
- AVVERTENZA - NON mettere questo prodotto vicino a una finestra perché i cordoni di tende o veneziane potrebbero comportare il rischio di strangolamento
- Stringere correttamente tutti i dispositivi di fissaggio
- Non utilizzare il prodotto se uno dei suoi componenti è rotto, danneggiato o mancante e utilizzare solo parti di ricambio approvate dal costruttore.
- Età del bambino al quale è destinato il prodotto: ≥ 6 anni
- Conforme alla norma EN 17191 :2021
- Carico massimo : 75 kg

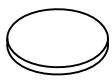
## NL BELANGRIJK! BELANGRIJK! AANDACHTIG DOORLEZEN EN BEWAREN VOOR LATERE RAADPLEGING

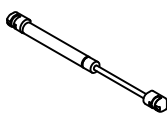
- Moet door een volwassene worden gemonteerd. Voor gebruik moet een volwassene controleren dat het product goed in elkaar is gezet
- WAARSCHUWING! schroeven en kleine elementen en zakjes buiten bereik van kinderen houden
- De elementen goed identificeren alvorens met de montage te beginnen
- Neem bij problemen contact op met onze klantenservice
- Volg altijd de instructies van de fabrikant
- Niet op het product klimmen
- Onderhoud: maak schoon met een zachte en droge doek. In geval van grotere vlekken, veeg voorzichtig schoon met een licht bevochtigde en niet-schurende spons
- WAARSCHUWING - Als dit product onder een raam wordt geplaatst, kan het door een kind als opstapje worden gebruikt waardoor het kind uit het raam kan vallen.
- WAARSCHUWING - Houd rekening met de risico's veroorzaakt door open vuren en andere sterke warmtebronnen in de nabijheid van het product
- WAARSCHUWING - Plaats dit product NIET in een buurt van een raam waar het koord van een jaloezie of gordijn een kind kan wurgen
- Zorg dat alle bevestigingen op elk moment juist zijn vastgemaakt.
- Gebruik dit product niet als er een onderdeel stuk of gescheurd is of ontbreekt. Gebruik alleen reserveonderdelen die door de fabrikant zijn goedgekeurd
- Leeftijd van het kind waarvoor de zitting is bestemd: ≥ 6 jaar
- Volgens EN 17191 :2021 norm
- Maximale belasting : 75 kg

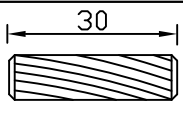

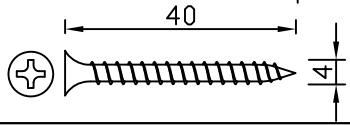
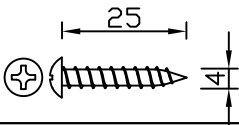

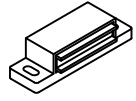
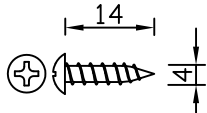
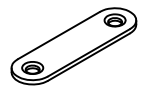
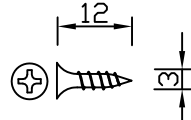
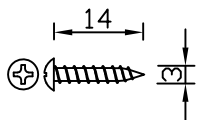
		Jx4	
Ax8		Kx1	
Bx8		Lx1	
Cx16		Mx1	
Dx10		Nx8	
Ex3		Ox1	
Gx5		Px1	
Hx17		Qx2	

# 1

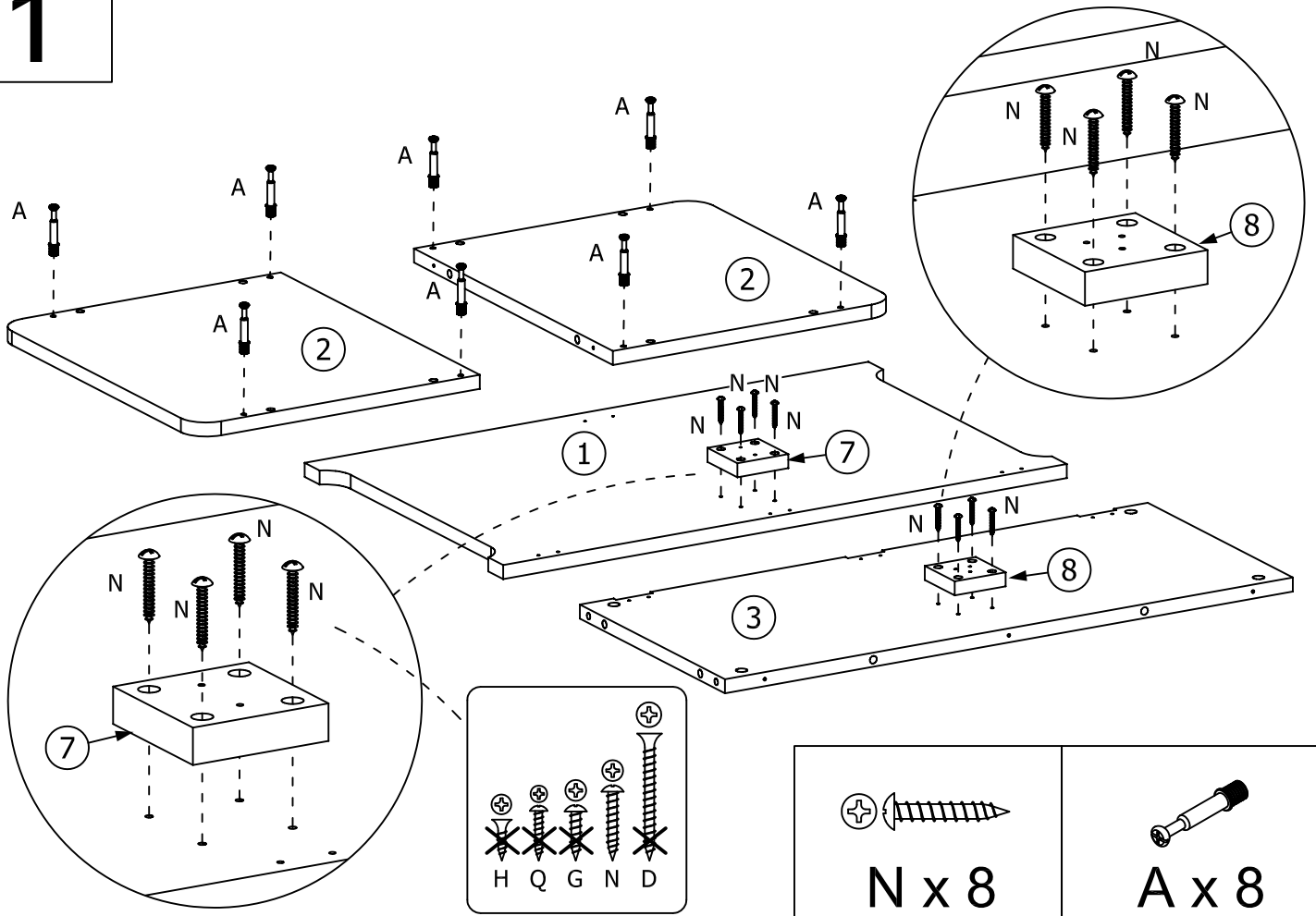

# 2

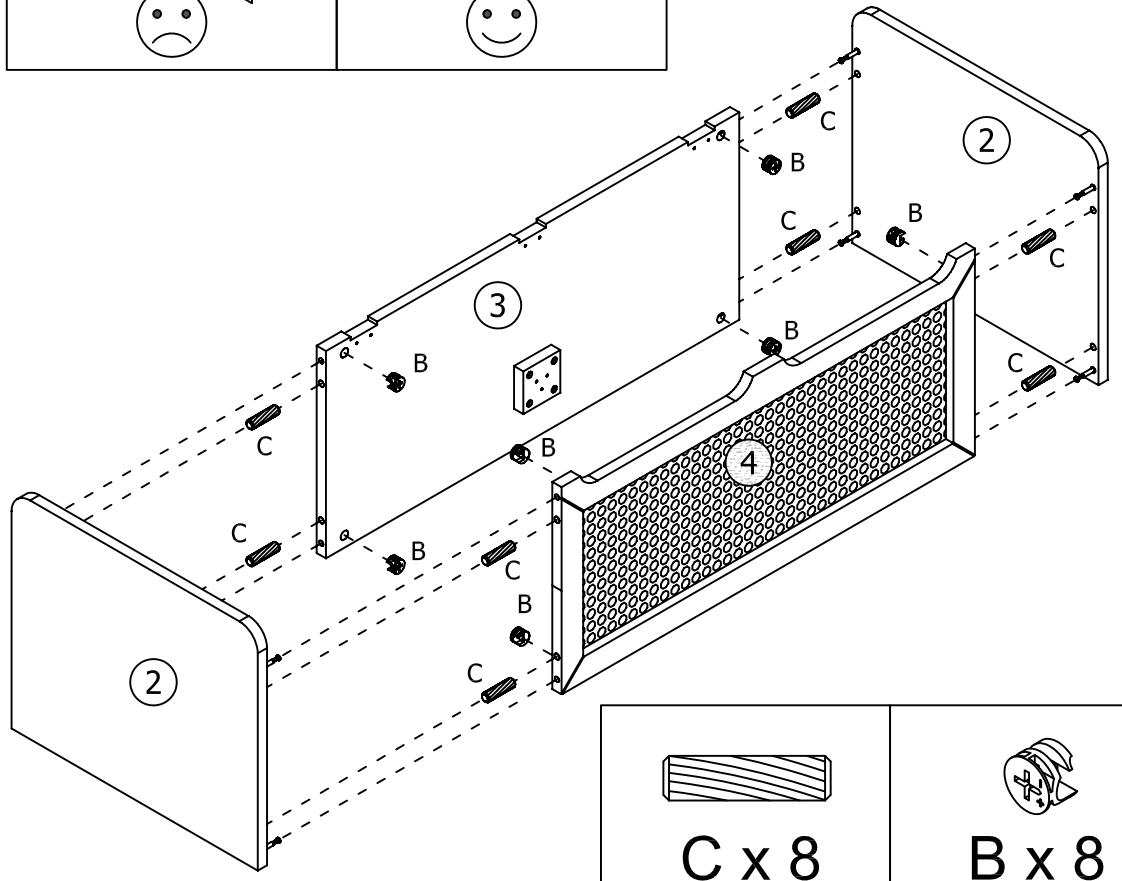
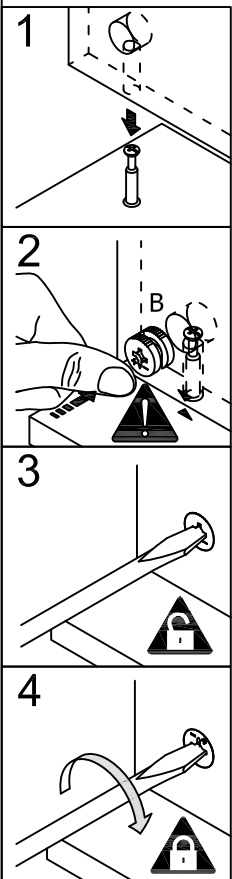
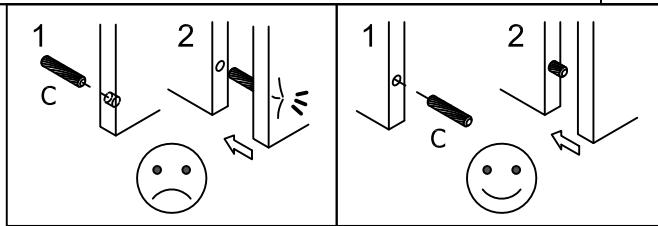



# 3

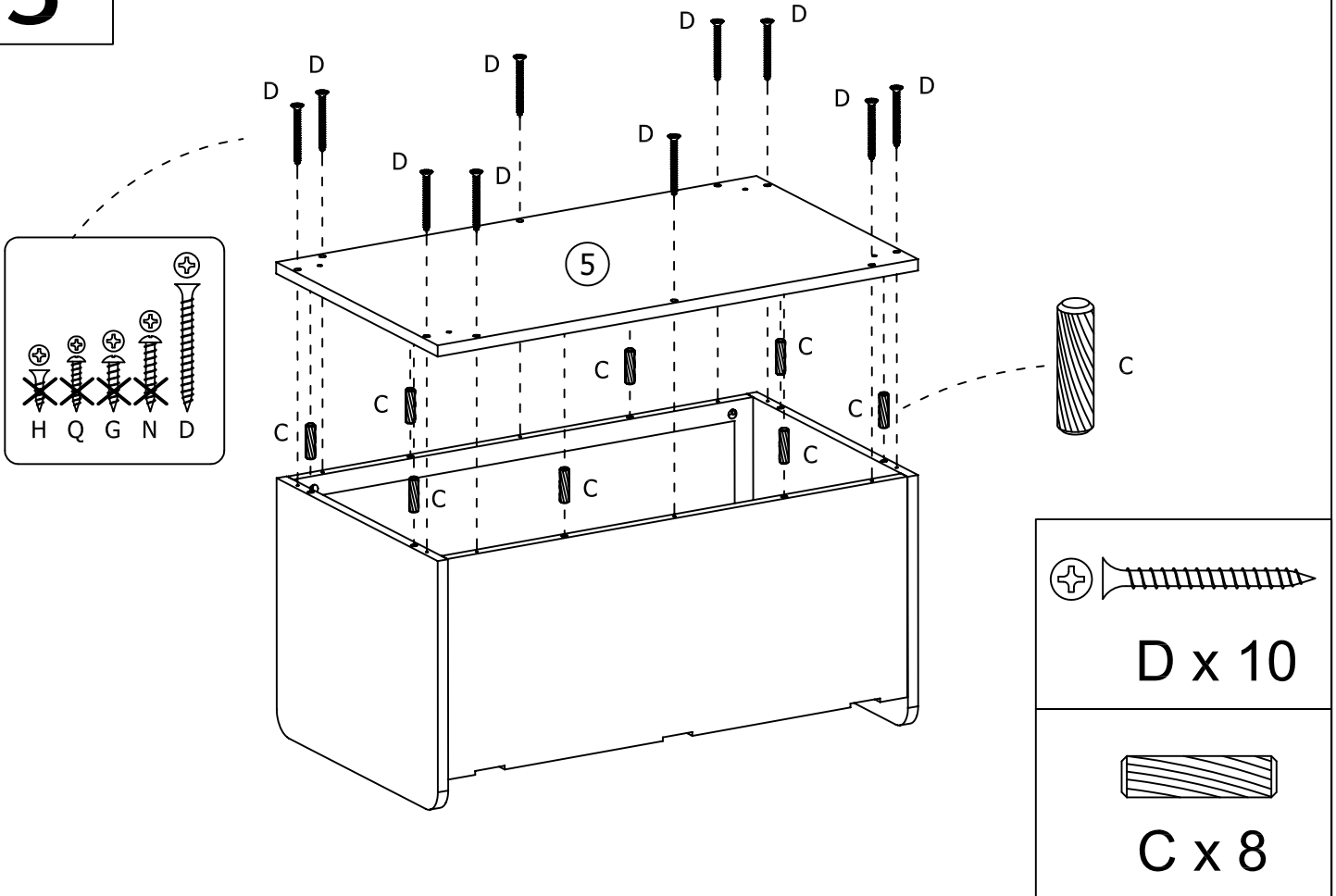

# 4

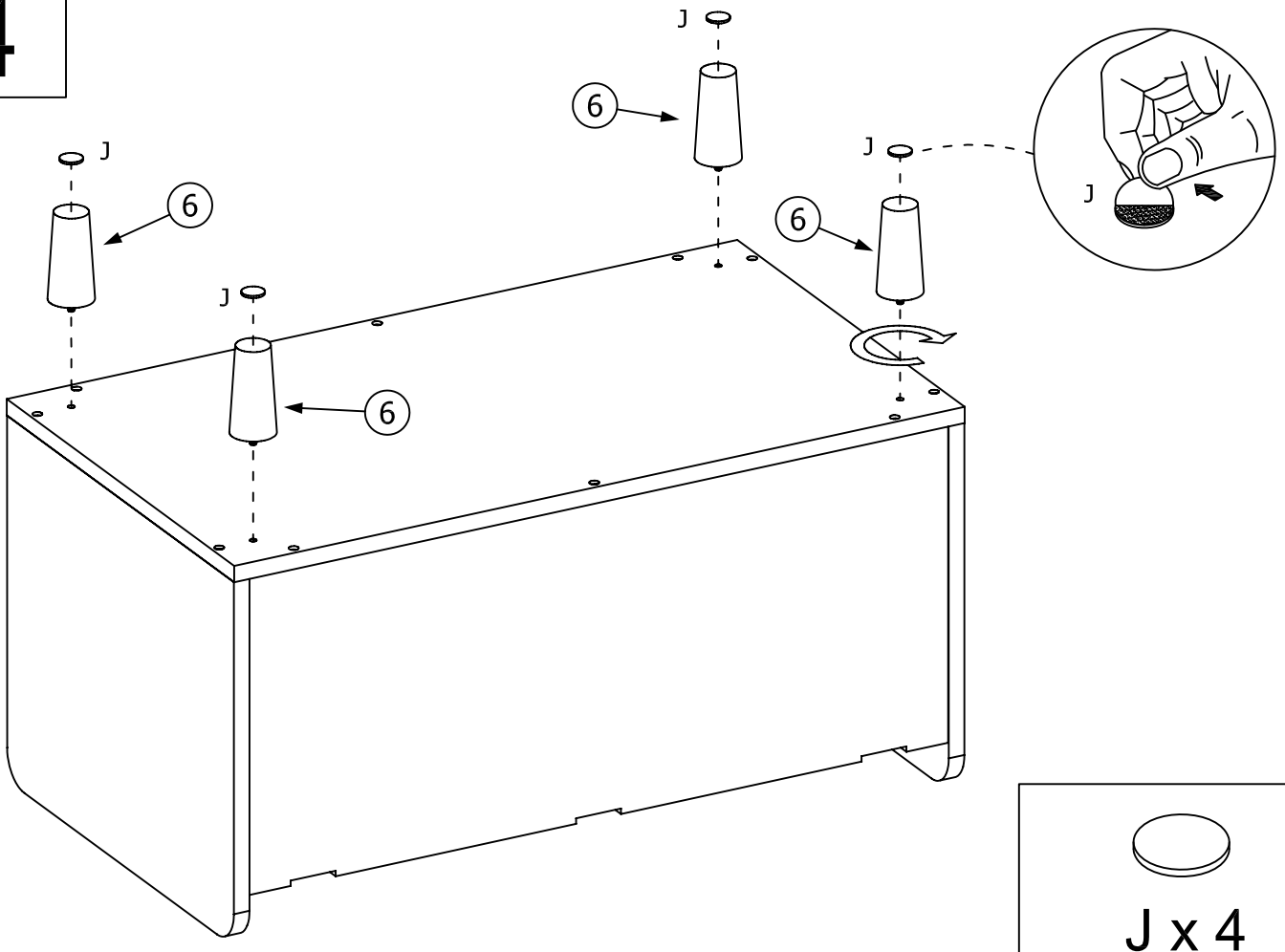

5

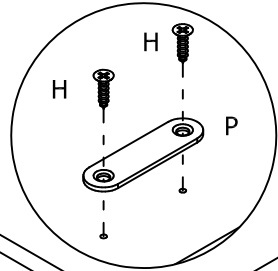
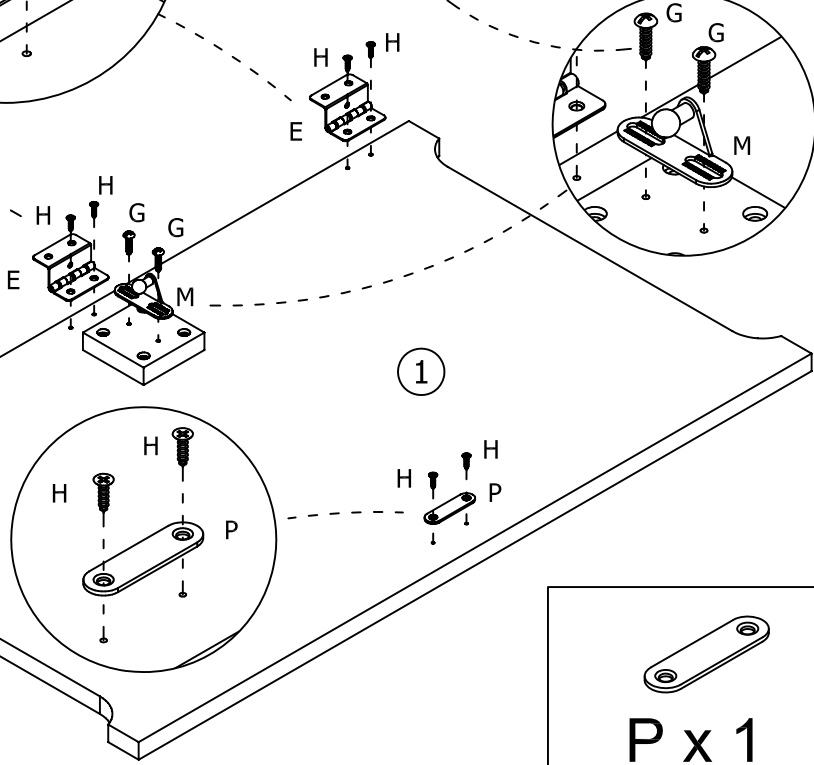
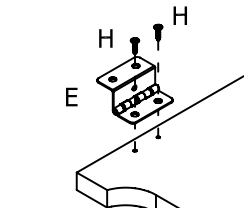
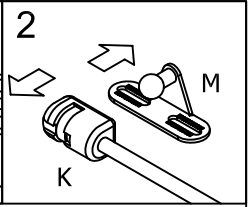
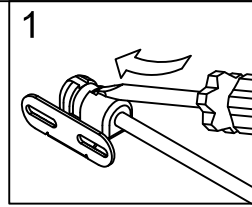
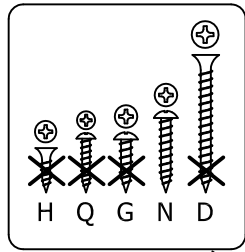
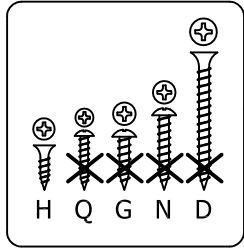

E x 3

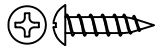

G x 2

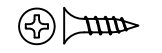

H x 8

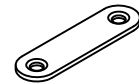

P x 1



M x 1

6

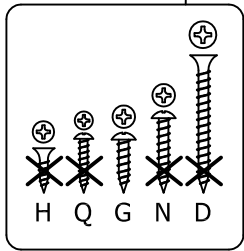
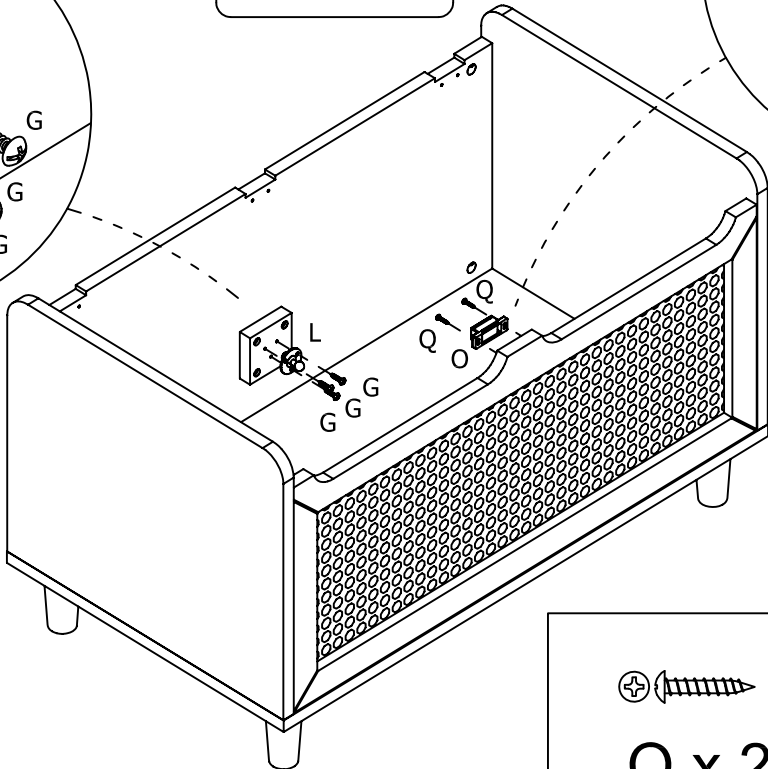
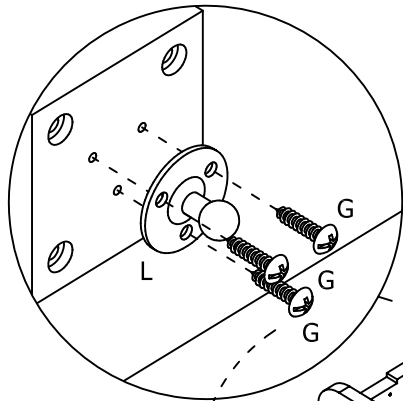
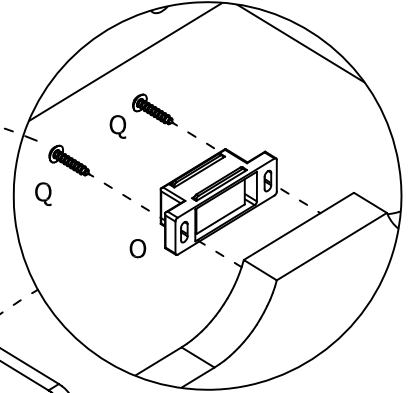
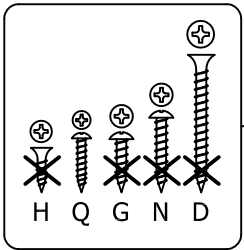

G x 3



L x 1

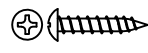

Q x 2

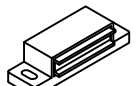

O x 1

7

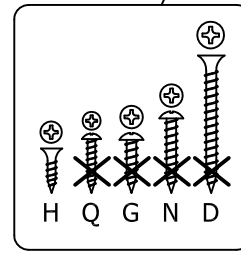
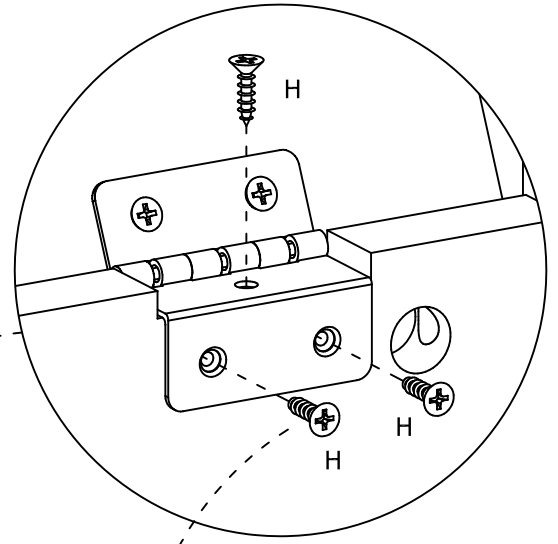
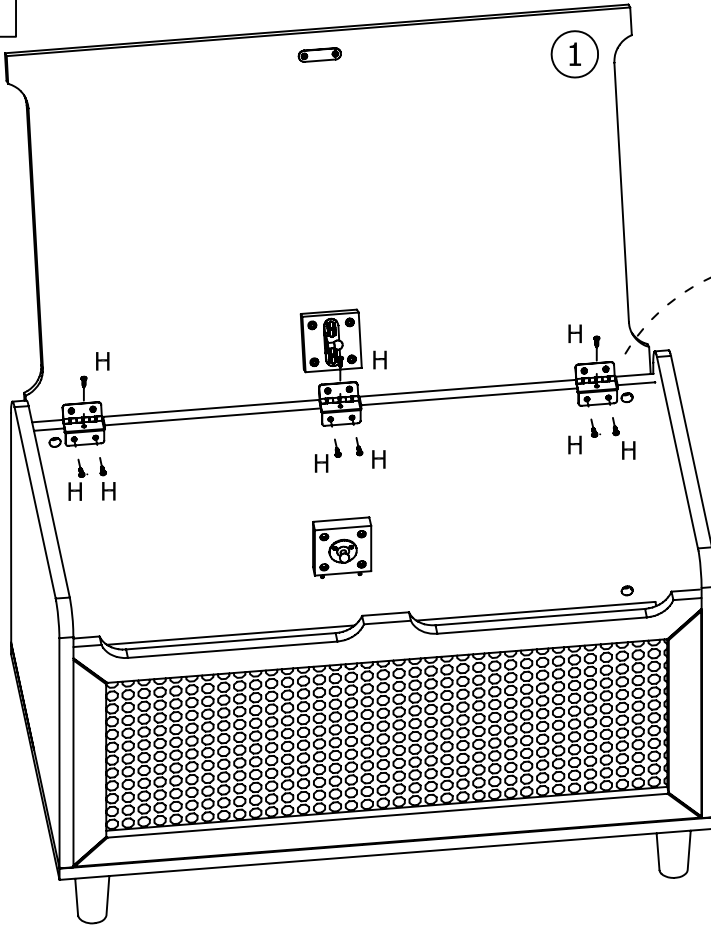

H x 9

8

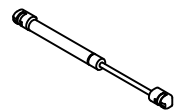
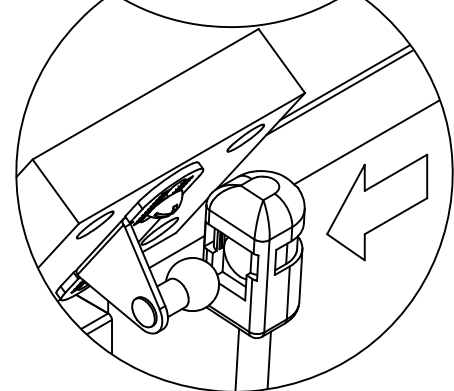
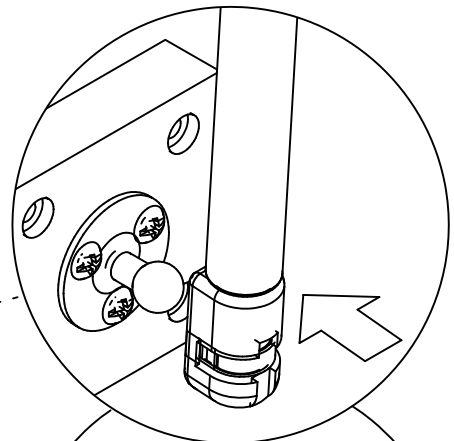
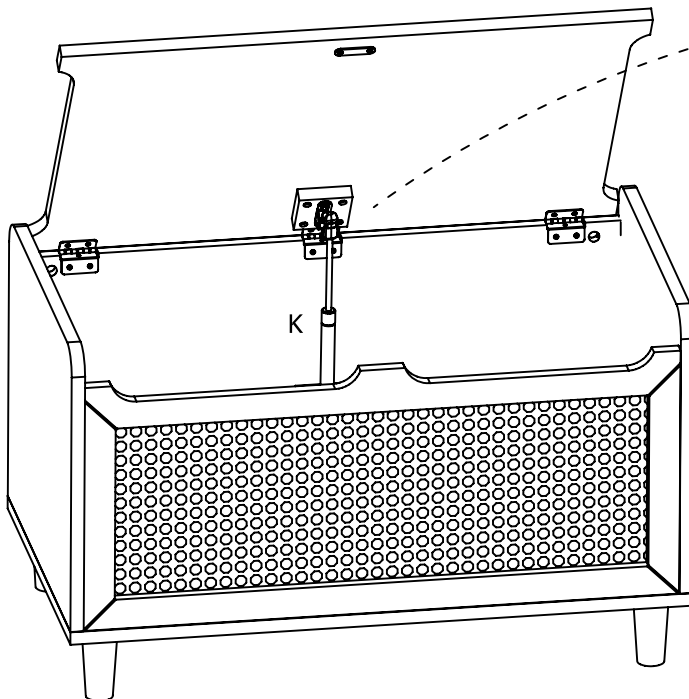

K x 1

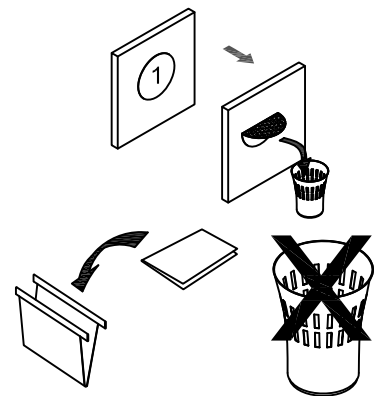
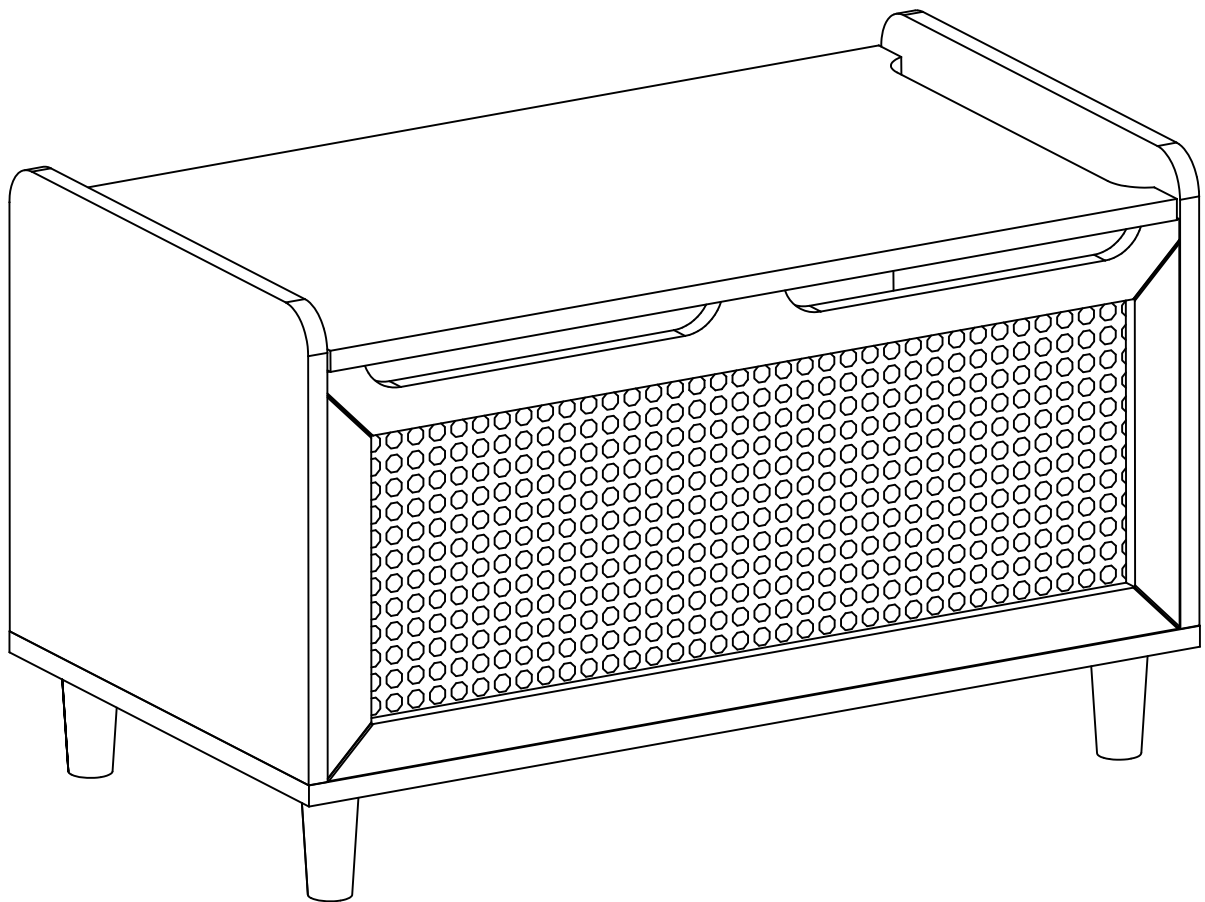

FR - Importé par / EN - Imported by / PT - Importado por / ES - Importado por  
/ DE - Importiert von / IT - Importato da / NL - Geïmporteerd door :  
UE/EU : Vertbaudet SAS - 216 Rue Winoc Chocqueel, 59200 Tourcoing, France  
UK: Vertbaudet UK Limited - Elder House, St Georges Business Park, 207 Brooklands  
Road, Weybridge, Surrey KT13 0TS